

TIMKEN**The Timken Company**

4500 Mt Pleasant St. NW

N. Canton, OH 44720

Phone: (234) 262-3000

E-Mail: CustomerCAD@timken.com • Web site: www.timken.com

Part Number 3209 AJ/2RS, Timken® Double Row Angular Contact Ball Bearings (3200, 3300)

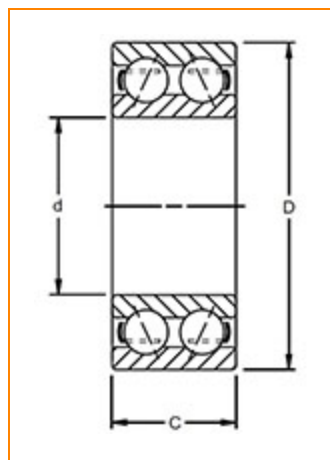

[Dimensions](#) | [Specifications](#) | [Basic Load Ratings](#) | [Abutment and Fillet Dimensions](#)

Dimensions

d - Bore	45.00 mm 1.7717 in
D - Outer Diameter	85.00 mm 3.3465 in
C - Ring Width	30.2 mm 1.1890 in
Contact Angle	30 °

Specifications

Features	Contact Seals
Ball Type	STEEL



Cage Type	Pressed
Cage Material	Steel
Bearing Weight	0.71 Kg 1.563 lb
Design Units	METRIC

Basic Load Ratings

C0 - Static Radial Rating	32600 N 7327 lbf
C1 ISO - Dynamic Radial Rating	40000 N 8991 lbf

Abutment and Fillet Dimensions

R - Inner Ring "To Clear" Radius ¹	1.10 mm 0.043 in
r - Outer Ring "To Clear" Radius ²	1.10 mm 0.043 in
da - Inner Ring Backing Diameter	52.0 mm 2.047 in
Da - Outer Ring Backing Diameter	78.00 mm 3.0710 in

¹ Maximum housing fillet radius that bearing corners will clear.

² Maximum shaft fillet radius that bearing corners will clear.

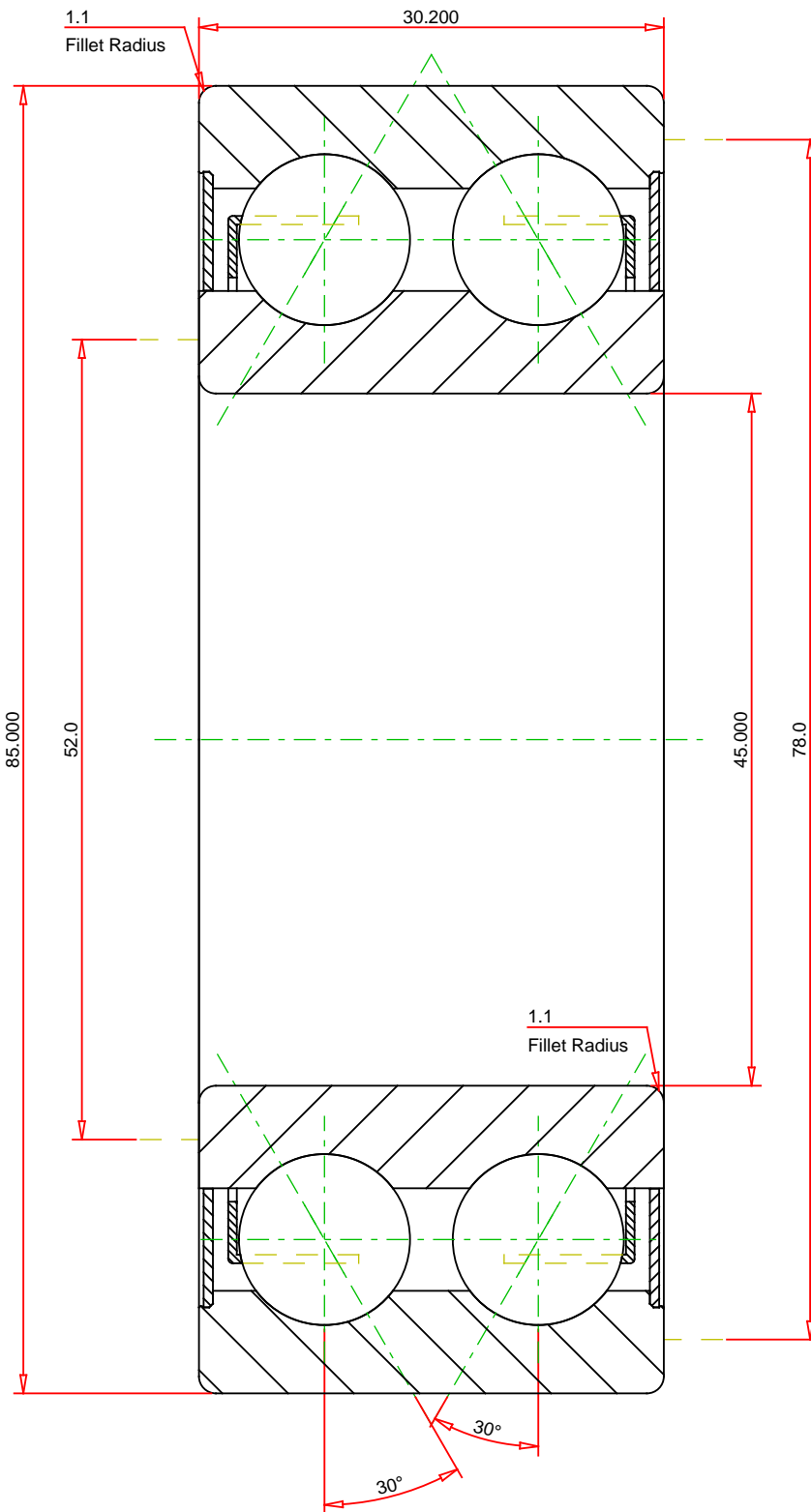

METRIC UNITS

Number of Balls Per Row	10
Bearing Weight	0.710 kg

TIMKEN®

THE TIMKEN COMPANY
NORTH CANTON, OHIO USA

3209 AJ/2RS
Timken® Double Row Angular Contact Ball Bearings
(3200, 3300)

Dynamic Load Rating	40000	N
Static Load Rating	32600	N

Every reasonable effort has been made to ensure the accuracy of the information contained in this writing, but no liability is accepted for errors, omissions or for any other reason.

FOR DISCUSSION ONLY